

## Series HPC 500 Medium Duty Class B Complete Cranes

For medium duty crane applications, the Series HPC 500 crane combines economy and performance. Crane travel is easy and smooth, thanks to machined wheels with sealed ball bearings, while the electric or manual hoist with matching trolley provides positive, controlled lifting motion. All bolted assembly makes installation quick and easy—no welding required. Select Series HPC 500 cranes when you need lifting power, economy, and flexibility for a wide variety of industrial uses.

### Capabilities to count on:

- Capacities in push operation: 1/2, 1 and 2 Ton up to 24' spans, in both top running and underhung designs.
- Fabricated from structural steel for optimal strength and rigidity.
- Large diameter wheels machined from cast iron and equipped with sealed deep groove ball bearings allow the crane to roll easily (wheels are suitable for flat or tapered flange beams).
- Rubber bumpers, drop stops, and rail sweeps are standard.



*Series HPC 500  
Top Running Push  
Complete Crane*

### Supplied components:

- End trucks.
- Bridge beam assembly with bracing.
- Trolley hoist available in a wide selection of low headroom styles.
- Documentation, including assembly and installation instructions, crane operator's guide, and owner's manuals.
- Touch-up paint.
- One year warranty.

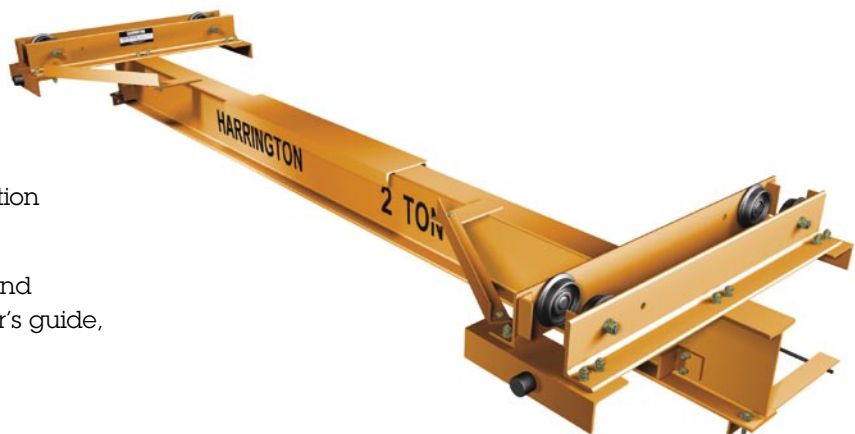

*Series HPC 500  
Underhung Push  
Complete Crane*

**SERIES 500 TOP RUNNING PUSH COMPLETE CRANES — SPECIFICATIONS & DIMENSIONS**

| Cap. (Tons) | Max. Span (ft) | Crane Product Code | Wheel Tread Dia. (in) | Rail Head Width* (in) | E** Beam Beyond Span (in) | M End Truck Frame Width (in) | N Runway Ctr. Line to Outer Edge of ET (in) | U Top of End Truck to Top of Beam (in) | Y Top of Rail to Top of End Truck (in) | System Max. Wheel Load*** (lbs/wheel pair) |
|-------------|----------------|--------------------|-----------------------|-----------------------|---------------------------|------------------------------|---|--|--|--|
| 1/2         | 24             | CHPC505            | 3.12                  | 1.5 – 6               | 6                         | T + 7.3                      | M/2   | Beam Depth                             | 4.3                                    | 841  |
| 1           |                | CHPC510            | 4.00                  |                       |                           | T + 8.3                      |   |  | 5.3                                    | 1500                                       |
| 2           |                | CHPC520            | 4.88                  |                       |                           | 5.9                          |   |  | 2819                                   |  |

\*Consult factory for widths greater than 6".

\*\*Minimum E is M/2.

\*\*\*See definition on page 26.

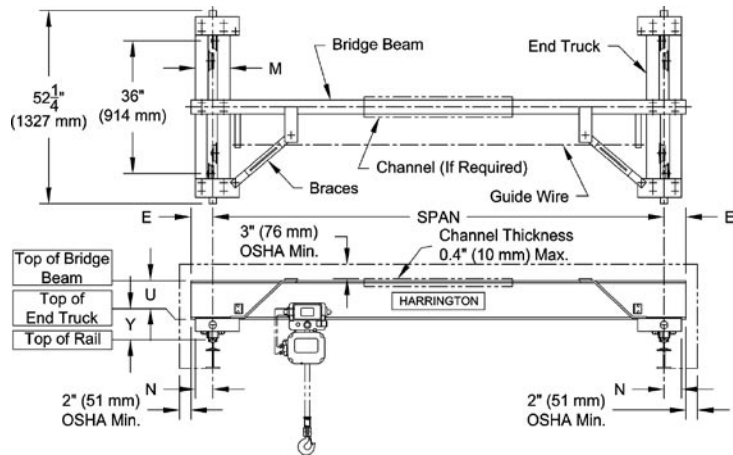

Series HPC 500  
Top Running Push  
Complete Crane

**SERIES 500 UNDERHUNG PUSH COMPLETE CRANES — SPECIFICATIONS & DIMENSIONS**

| Cap. (Tons) | Max. Span (ft) | Crane Product Code | Wheel Tread Dia. (in) | T* Flange Range Std. (in) | E** Beam Beyond Span (in) | M End Truck Frame Width (in) | N Runway Ctr. Line to Outer Edge of ET (in) | U Wheel Running Surface to Top of Beam (in) | Y Wheel Running Surface to Upper Most Part of Crane (in) | System Max. Wheel Load*** (lbs/wheel pair) |
|-------------|----------------|--------------------|-----------------------|---------------------------|---------------------------|------------------------------|---|---|--|--|
| 1/2         | 24             | CHPC505            | 3.12                  | 3 – 6                     | 12                        | T + 7.3                      | M/2   | 1.2   | 3.6  | 846  |
| 1           |                | CHPC510            | 4.00                  |                           |                           | T + 8.3                      |   | 1.2   | 4.4  | 1506                                       |
| 2           |                | CHPC520            | 4.88                  | 3.3 – 6                   |                           | 1.1                          |   | 5.3   | 2827   |  |

\*Consult factory for widths greater than 6".

\*\*Minimum E is M/2.

\*\*\*See definition on page 26.

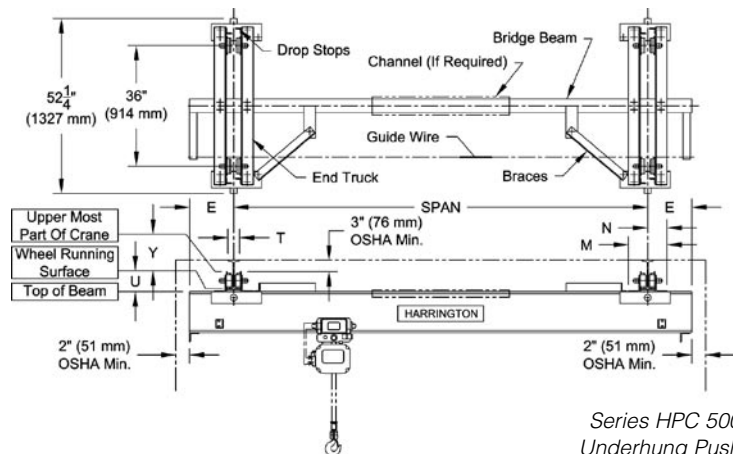

Series HPC 500  
Underhung Push  
Complete Crane